

SMD Crystal Resonators / MHz Band Crystal Resonators

DSX21 1G (For Industrial Equipment)

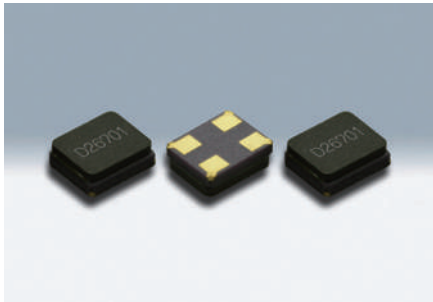

Actual size

Features

- 2016 size miniature and lightweight SMD crystal resonator with a low profile of 0.65mm.
- High precision and high reliability
- Offers a wide range of frequencies from 20MHz up to 64MHz.
- Utilizing vacuum glass sealing, lower ESR equivalent to that in alloy/seam weld sealing is optionally available.
- Moisture prevention packing is unnecessary. Moisture Sensitivity Level: LEVEL 1 (IPC/JEDEC J-STD-033)
- AEC-Q200 Compliant

Applications

- Industrial equipment
- Telecommunication products and other small devices such as DVC, DSC, PDA, PC, USB.
- Automotive applications such as multimedia devices (AEC-Q200 Compliant).

Standard Specification

Item	Type	DSX21 1G			
		20 ~ 24MHz	24 ~ 30MHz	30 ~ 36MHz	36 ~ 64MHz
Frequency Range		20 ~ 24MHz	24 ~ 30MHz	30 ~ 36MHz	36 ~ 64MHz
Overtone Order		Fundamental			
Load Capacitance		8pF, 10pF, 12pF			
Drive Level		10μW (100μW max.)			
Frequency Tolerance		±20×10 ⁻⁶ (at 25°C)			
Series Resistance(Inside Atmosphere:nitrogen)		200Ω max.	150Ω max.	120Ω max.	80Ω max.
Series Resistance(Inside Atmosphere:vacuum)		150Ω max.	100Ω max.		60Ω max.
Frequency Characteristics over Temperature		±50×10 ⁻⁶ / -40 ~ +105°C (Ref. to 25°C)			
Storage Temperature Range		-40 ~ +105°C			
Packing Unit		3000pcs./reel (φ 180)			

Consult our sales representative for other specifications.

[mm]

Dimensions

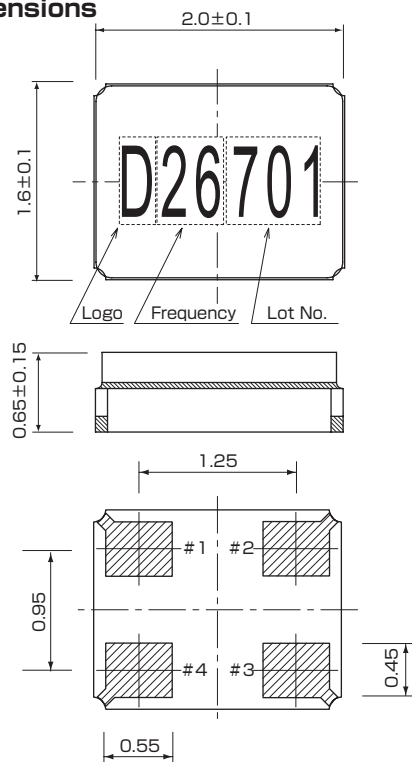

Internal Connections

<Top View>

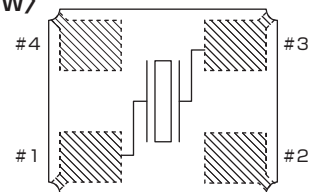

#1 & #3 connected to quartz element
#2 & #4 open (unconnected)

Recommended Land Pattern

<Top View>

